

Please, read this manual
carefully before use!

Owner's manual



HEAVY DUTY

Diesel Generator

KS 6100HDE

KS 8100HDE-1/3 ATSR

KS 8100HDE

KS 9100HDE-1/3 ATSR

Silent Diesel Generator

KS 8200HDES-1/3 ATSR

KS 9200HDES-1/3 ATSR

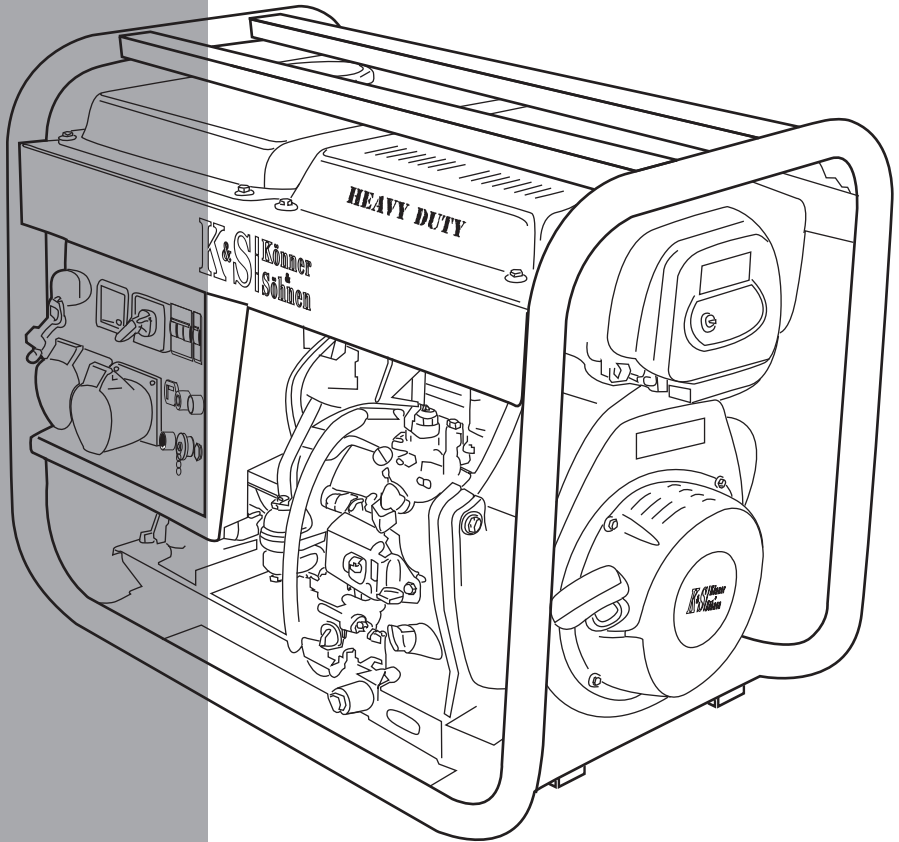

CONTENTS

1. Introduction	2
2. Safety information	3
3. Main overview	5
4. Models description	6
5. Terms of use	7
6. Before starting	10
7. Starting to work	11
8. Technical maintenance works	15
9. Maintenance schedule	16
11. Recommended oils	17
12. Air filter maintenance	18
13. Fuel filter technical maintenance	19
14. Accumulator maintenance	19
13. Generators` storage	20
14. Possible failures and solutions	21
15. Average power usage	22
16. Warranty terms and conditions	23

Abbreviations meaning:

KS	Generator
D	Diesel
E	Electric start
3	Three-phase generator
ATS	Automatic transfer switch
ATSR	ATS-input



ATTENTION - DANGER!



Failure to follow the recommendations marked with this sign may lead to serious injury or death of the operator or third parties.



IMPORTANT!



Useful information while operating the machine.

INTRODUCTION

We are grateful to you for your purchase of **TM Könnner & Söhnen** series diesel generator. This manual contains safe working recommendations, operation and adjustment description of these generators and maintenance instructions.

Manufacturer reserves the right to make alterations into the generators, which may not be reflected in this manual. Pictures and photos of the product may vary from its actual appearance. At the end of this manual, You may find contact information which you are free to use in case of any issues occurrence.

All data, specified in this operation manual is the most up to date for the moment of its publishing.



In order to provide equipment integrity and avoid any possible injuries we strongly recommend You to carefully read this manual before operating the generator.

The current list of service centers you can find at the website of official importer:

www.ks-power.de

SAFETY INFORMATION

Carefully read this manual before starting to work with the generator

Working area

- Please don't use the generator near flammable gases, liquids or dust. When using the generator exhaust system gets very hot. This may cause fire or explosion of these materials.
- Be sure to follow cleanliness and good lighting in the work area. Clutter and poor lighting may cause an injury.
- Do not let the presence of unauthorized persons, children or animals when working with generator. If necessary, make sure to fencing the working area.

Electrical safety

- The generator produces electricity that may lead to an electric shock while neglecting compliance regulations.
- In the high humidity level conditions generator exploit is prohibited. Keep the generator in a dry place only.
- Avoid direct contact with grounded surfaces (pipes, radiators, etc.).
- Do not allow moisture in the generator. The water inside the device increases the risk of an electric shock.
- Be careful when working with power cables. Immediately replace it in case of damage, as damaged wire increases the risk of electric shock.
- All connecting the generator to the network must be made by certified electrician in accordance with all electrical rules and regulations.
- Connect the generator to the protective ground before operation.
- Do not connect or disconnect a generator to electricity consumers, which are placed in water on a wet or damp soil.
- Do not touch parts of the generator under voltage.
- Connect the generator to those customers only which meet the electrical characteristics and the rated power of the generator.
- Store all electrical equipment dry and clean. Wires with damaged or spoiled insulation should be replaced. You should also replace worn, damaged or rusty contacts.

Personal safety

- Be careful. Do not operate the generator, if you are tired, under the influence of drugs or alcohol. Inattention may cause a serious injury.
- Do not wear loose clothing or jewelry when working. Long hair, jewelry or loose clothing may get into the moving parts of the generator and cause an injury.
- Avoid inadvertent start. Make sure to set the switch to Off when you turn off the generator.

- Make sure no outsider objects are on the generator when it is turned on.
- Always keep a stable position and balance when starting the generator.
- Use safety equipment. Always wear goggles, a mask, non-slip sole shoes, protective helmet, headphones.
- Do not overload the generator, use it only for the purpose. Proper use of the generator will do the job for which it is designed better and safer.
- To avoid inhaling exhaust gas, the generator does not have to work in conditions of poor ventilation. Exhaust gas contains poisonous carbon monoxide. Use and maintenance of the generator.
- Before you start checks before operating, make sure that the generator is on a flat level surface and the engine switch is set to Off.
- Keep the generator dry, well ventilated place if you are not using it.
- Check the connection of moving parts, no damaged parts that affect the operation of the generator. If the generator is damaged, remove them before using.
- For repair and maintenance use only recommended oil fuel. Using other lubricants, spare parts and consumables deprives you of warranty apparatus.
- Labels and stickers on the generator and engine leave because they contain important information.
- Servicing the generator should be carried out only by qualified personnel.
- When servicing the generator follow all instructions of this manual.



IMPORTANT!



The generator runs on diesel fuel. Do not use gasoline or kerosene as fuel.

MAIN OVERVIEW

Pic 1

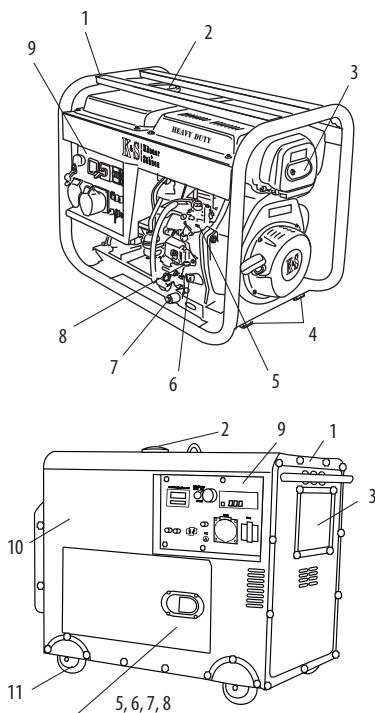

- | | |
|---------------------------|----------------------------|
| 1. Reinforced steel frame | 7. The oil drain hole |
| 2. Fuel tank cap | 8. Emergency switch engine |
| 3. Air filter | 9. Maintenance panel |
| 4. Antivibration supports | 10. Soundproof housing |
| 5. Fuel pump | 11. Wheels |
| 6. Oil dipstick | |



IMPORTANT!



Manufacturer reserves the right to make changes and/or improvements in design, components set and technical attributes without notice and without incurring obligation. The pictures in this manual are schematical and may not match the parameters of original product

MODELS DESCRIPTION

Model	KS 6100HDE	KS 8100HDE	KS 8100HDE-1/3 ATSR	
Voltage, V	230	230	230	400
Max Power, kW	5.5	6.5	5.3	6.5
Nominal Power, kW	5.0	6.0	4.8	6.0
Power factor, cosφ	1.0	1.0	1.0	0.8
Current max, A	23.91	28.26	23.04	11.74
Frequency, Hz	50	50	50	
Outlets	1*32A 1*16A	1*32A 1*16A	1*32A 1*16A (3p)	
Fuel Tank Volume, l	15	15	15	
LED display	voltage frequency working hours	voltage frequency working hours	voltage frequency working hours	
Noise level L _{PA} /L _{WA} , dB	71 / 96	71 / 96	71 / 96	
Power output V/A	12/8,3	12/8,3	12/8,3	
Engine model	KS 440HD	KS 480HD	KS 480HD	
Engine type	4-stroke diesel	4-stroke diesel	4-stroke diesel	
Engine power, hp	12.0	14.0	14.0	
Crank case volume, cm ³	1,65	1,65	1,65	
Engine cylinder volume cm ³	418	456	456	
Power output controller	AVR	AVR	AVR	
Engine start	manual/ electric	manual/ electric	manual/electric	
Dimensions (L*W*H), mm	765*530*630	765*530*630	765*530*630	
The diameter of the frame	32 mm round	32 mm round	32 mm round	
Battery, Ah	30	30	30	
Fuel heater	+	+	+	
Output for ATS	-	-	+	
Weight, kg	107	117	117	

Acceptable deviation of a current is 5%

MODELS DESCRIPTION

Model	KS 8200HDES-1/3 ATSR		KS 9100HDE-1/3 ATSR		KS 9200HDES-1/3 ATSR	
Voltage, V	230	400	230	400	230	400
Max Power, kW	5.5	6.5	6.4	7.5	6.4	7.5
Nominal Power, kW	5.0	6.0	5.9	7.0	5.9	7.0
Power factor, cosφ	1.0	0.8	1.0	0.8	1.0	0.8
Current max, A	23.04	11.74	27.83	13.54	27.83	13.54
Frequency, Hz	50		50		50	
Outlets	1*32A 1*16A (3p)		1*32A 1*16A (3p)		1*32A 1*16A (3p)	
Fuel Tank Volume, l	15		15		15	
LED display	voltage frequency working hours		voltage frequency working hours		voltage frequency working hours	
Noise level L _{PA} /L _{WA} , dB	69 / 94		71 / 96		69 / 94	
Power output V/A	12/8,3		12/8,3		12/8,3	
Engine model	KS 480HD		KS 520HD		KS 520HD	
Engine type	4-stroke diesel		4-stroke diesel		4-stroke diesel	
Engine power, hp	14.0		18.0		18.0	
Crank case volume, cm ³	1,65		1,65		1,65	
Engine cylinder volume cm ³	456		498		498	
Power output controller	AVR		AVR		AVR	
Engine start	electric		manual/electric		electric	
Dimensions (L*W*H), mm	950*550*880		765*530*630		950*550*880	
Housing	Soundproof housing		Reinforced steel frame 32 mm		Soundproof housing	
Battery, Ah	30		30		30	
Fuel heater	+		+		+	
Output for ATS	+		+		+	
Weight, kg	163		122		168	
Acceptable deviation of a current is 5%						

To ensure the reliability of the generator and increase its lifespan, the peak capacities may be slightly limited by circuit breakers.

The optimum operating conditions are ambient temperature of 17 – 25 °C, barometric pressure of 0.1 MPa (760 mm Hg), and relative humidity of 50 – 60%. Under such ambient conditions, the generator can guarantee maximum performance in terms of the stated specifications. In case of deviations from the above ambient values, the performance of the generator can be different.

Please note that in order to preserve the lifespan of the generator, continuous loads should not exceed 80% of the rated power.

TERMS OF USE

When starting operating the generator, it's recommended to ground it. Before starting the unit, remember that the total power of consumers connected should not exceed the rated capacity of the generator.

Types of consumers and inrush current

Consumers (electrical devices connected to the generator) are divided into active and reactive ones. Active ones are those, which energy is converted into heat (heating devices).

Reactive are all consumers with electric motor. When you run the engine, starting currents occur briefly, the size of which depends on engine design and purpose. Please consider those starting currents when choosing a generator.

Most electric tools have starting current ratio 2-3. This means that when you turn such tools required generator power have 2-3 times more power load. The biggest factor of inrush current have such consumers as compressors, pumps, washing machines.

BEFORE STARTING

Check the fuel level

1. Remove the fuel tank cap and check the fuel level.
2. Fill fuel to the level of the fuel filter and make sure there is no air in the fuel system.
3. Screw the fuel tank cap back tightly.

Check the oil level (Pic 2)

1. Unscrew the oil level gage and clean it with clean cloth.
2. Put the oil gage back without screwing it.
3. Take the oil level gage out and check the oil level according to the mark on a gage.
4. Add oil if it's level is below the mark on a gage.
5. Screw the oil gage back.



For commissioning models with electric it is necessary to charge the battery. Charge the battery with additional battery charger (not included) or let the generator work at least one hour at 50% load.



IMPORTANT!



Diesel fuel type should correspond the operating season.

MAINTENANCE PANEL

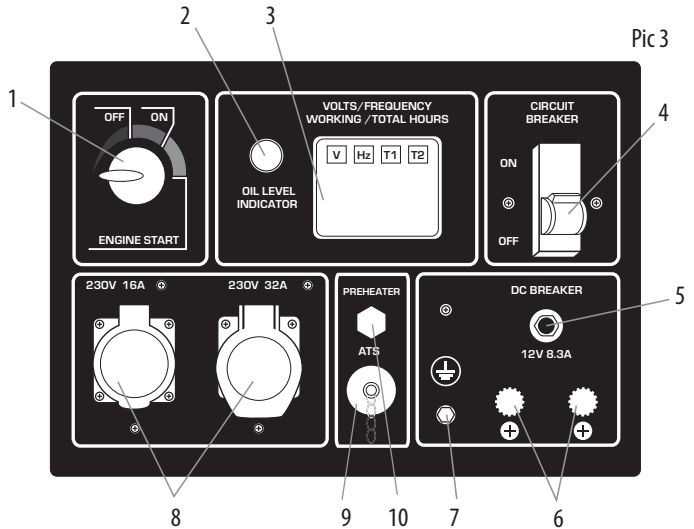

- | | |
|---|--------------------------------|
| 1. Engine start | 5. DC breaker |
| 2. Oil level indicator | 6. Direct current sockets 12 V |
| 3. LED-display: | 7. Grounding |
| V - voltage | 8. Sockets |
| Hz - frequency | 9. Output for ATS |
| T1 - current time (since the last start) | 10. Fuel heater |
| T2 - total time (since the commissioning) | |
| 4. Circuit breaker | |

STARTING TO WORK

Ensure that the power tool or consumers meet **current capabilities of the generator** before starting the engine. It is prohibited to exceed its rated capacity. **Do not connect the device before starting the engine!**



IMPORTANT!



Do not change the configuration of the amount of fuel or speed controllers (this adjustment was made before the sale). Otherwise, there will be possible changes in the engine work or breakage.



ATTENTION - DANGER!



Do not let the generator work more than 30 minutes in range from nominal to maximum.

Manual start

- Do not connect any devices before you start the engine.
- Connect the positive terminal of the battery.
- Turn the motor safety switch (Fig. 4) to ON position.

Pic 4

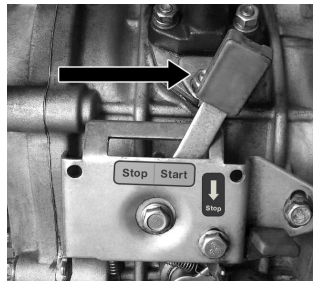

Pic 5



- Pull the starter handle until you feel resistance.
- Remove the rubber plug on the top cover of the generator, which is under decompressor lever (Pic 5); push the decompressor at the top of cylinder head to reduce pressure in the cylinder and relief extension.
- Vigorously pull starter handle and start the engine.
- Do not let a sharp return to starter motor. To avoid starter damage, return it to the original position carefully.
- After three minutes of the generator work, switch machine protection (Emergency switch) in the upper position ON.

Electric start

- Do not connect any devices before you start the engine.
- Connect the positive terminal of the battery.
- Turn the motor safety switch to ON position.
- Set the key to ON position.
- Turn the key clockwise to START position.
- After the engine launch, release the key, and it will automatically return to ON position.
- If the engine doesn't start after keeping the key in START position for 10 seconds, wait 15 seconds before trying start again. The battery can discharge after continuous work of launch engine system. Leave the key in ON the position during work.
- After three minutes of the generator work, switch machine protection (Emergency switch) in the upper position ON.



IMPORTANT!



If engine does not start after three or four attempts, it may mean that the fuel system has some air inside.



ATTENTION - DANGER!



Do not let the simultaneous connection of two or more devices. Start of many devices requires large power capacity. Devices are to be connected in turns, according to its maximum allowed power. Do not connect the consumers in first 3 minutes after the generator start.

Before turning the generator on, verify that the connected devices are in working order. If the connected device suddenly stops running – turn the power off by means of an emergency switch, disconnect the device and check it.

Starting with electric starter in the cold season

When the air temperature is lower than +5°C it is necessary to use the «Warming-up» function when starting. Turn the ignition key to ON position and push the heating button. Hold it and turn the ignition key to START position.



IMPORTANT!



Do not hold the ignition key in «Warming-up» position more than 15 seconds, it may cause the failure of incandescent candles.

Disconnect all devices before stopping the generator. Do not stop the generator, if there are any devices connected. This may result to generator breakdown.

During generator operation:

- You may use the generator, if the voltage meter displays the value 230V+/- 10% (50 Hz) and 400V+ / - 10% (50 Hz) for three-phase generator.
- Watch the voltage meter and in case of excessive indices values, stop the generator operation.
- Connection to continuous voltage socket is used for accumulator recharge only. Upon accumulator unit recharge, it is mandatory to verify the polarity correctness (+ to +, - to -).
- Charging device wires have to be at first connected to the accumulator unit and only then – to the generator itself. All “generator to network” connections are to be carried out by a certified electrician. Any mistakes may result in serious equipment damage.
- It is forbidden to use 12V voltage simultaneously with 230V (400V for three-phase generators).

In order to stop the engine, perform the following actions:

1. Stop all power consuming devices connected to the generator, set the emergency switch to OFF.
2. Let the generator run at no load for 3 minutes for alternator to be cooled.
3. In case of manual start – set the engine switch to OFF position.
4. In case of electric start, turn the key to OFF position.
5. For all types of diesel generators there is an emergency stop lever for the engine. Use it in case of emergency only.

Commissioning

The first 20 hours of generator work please comply the following requirements:

- 1 During commissioning, do not connect the load which power exceeds 50% of the nominal (working) generator power.
2. Change the oil after commissioning. Its better to drain it before the engine cools down after work, in this case oil will drain faster.

Connecting devices

After starting the engine, make sure the voltmeter readings correspond to the nominal (at 50 Hz 230V + - 5% for single-phase units and 400 + -% for three-phase).

For three-phase diesel generator

Three-phase diesel generator load must be distributed on all three phases, and the load on all phases must be balanced. The load on 1 phase should not exceed 1/3 of the total generator capacity. Maximum permissible imbalance is 20%.

Only 1 or 2 phase load leads to the generator breakage. The total load and total current on all three phases should not exceed nominal load and current of the generator.

**IMPORTANT!**

Failure to follow these instructions may lead to damage of the rotor and stator windings, the AVR unit.

**IMPORTANT!**

An overload may lead to automatic activation of generator protection machine. Reduce the load. Reconnect the generator no earlier than 5 minutes after switching off.

TECHNICAL MAINTENANCE WORKS

Works, specified in “Technical maintenance” section, are to be regularly performed. If the the generator user has no possibility to perform regular maintenance independently, it is necessary to address the official service center to registrate an order for such works performance.

**IMPORTANT!**

In case of any damages, occurred due to non-performance of regular maintenance works, the manufacturer bears no responsibility for such damages.

Such damages are also:

- Damages occurred as a result of using non original spare parts;
- Corrosion damages and other results of improper equipment storage;
- Damages occurs as a result of maintenance performance by inexperienced and unauthorized specialists.

Manual compliance

Technical maintenance, operation and Könnert & Söhne™ generator storage are to be performed according to this manual recommendations. Manufacturer bears no responsibility for damages and losses, caused by incompliance to safety requirements and technical maintenance rules.

First of all this applies to:

- use of lubricants, gasoline and motor oils, forbidden by the manufacturer;
- device technical alterations;
- equipment operations against its intended use;
- indirect damages, caused by operating faulty equipment;

MAINTENANCE SCHEDULE

Unit	Action	Every start	First month or after 20 working hours	Each 3 months or after 50 working hrs	Each 6 months or after 100 working hrs
Motor oil	Checking the level	✓			
	Replacement		✓	✓	
Air filter	Cleaning		✓	✓	
	Change				✓
Oil filter	Cleaning		✓	✓	
	Replacement				✓
Fuel tank	Checking the level	✓			
	Cleaning		✓		✓
Fuel filter	Cleaning		✓		
	Replacement				✓

RECOMMENDED OILS

Motor oil has a serious impact on performance characteristics and is a major attribute, defining its service life. Use oils designed for four-stroke cycle vehicle engines, since such oils contain cleaning additives, which comply or even exceed SE standards according to API classification (or equivalent).

In general, the engine is recommended to run with motor oils of SAE10W-30 viscosity level. Motor oils with other viscosity levels, may be used only if the average air temperature in your region does not exceed the limits of the temperature range, specified in the table. Oil viscosity according to SAE standards or service category, are specified on the API capacity sticker.

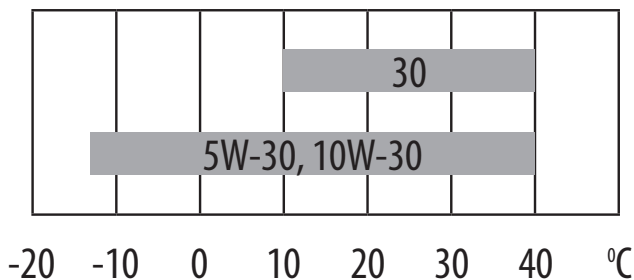

Engine oil replacement or adding

Upon oil level decrease it is necessary to add the required quantity in order to provide the correct generator operation. It is necessary to check the oil levels according to technical maintenance schedule.

To replace engine oil, perform the following actions:

1. Make sure that the generator is set on flat level surface.
2. Place a drain oil holding tank under the engine.
3. Turn the drain cap, located under the oil-depth gage cap in the engine, by means of a 10mm hexagon spanner.
4. Wait till the oil drains.
5. By means of a funnel, pour the advanced purification engine oil to the crankcase. The funnel is not included. Oil level after filling has to be close to the upper part of oil filler.
6. Put the drain cap back and tighten it well.

Pic 7

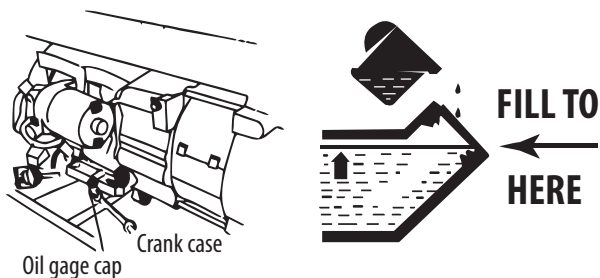

AIR FILTER MAINTENANCE

It is necessary to check the air filter from time to time and clean any contaminations. Regular air filter maintenance is necessary to maintain sufficient carburetor air inflow. The air filter should be cleaned more often when using generator in dusty conditions.



ATTENTION - DANGER!



Never run the engine with the air filter removed or without the filter. Otherwise dirt and dust lead to rapid breakage of engine parts. Failure in this case will not be repaired.



IMPORTANT!



Air filter replacement is to be performed each 100 hours of the generator operation (every 50 hours in unusually dusty conditions).

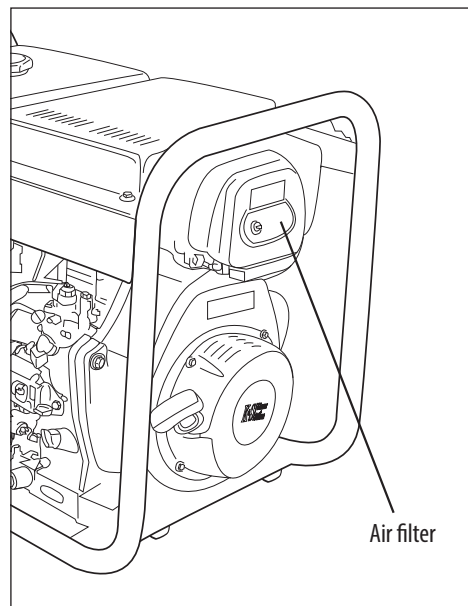

Pic 8

FUEL FILTER TECHNICAL MAINTENANCE

There are two kinds of fuel filters in **Könner & Söhnen** diesel generators. They prevent the ingress of contaminants from diesel fuel to the engine.

Coarse cleaning fuel filter

Remove the filter after the possible hard particles hit every 500 operating hours. Never use water for purification the filter.

1. Remove the fuel cap.
2. Remove the fuel filter.
3. Use diesel fuel to clean the filter.
4. Put the filter back to the fuel tank.

The fuel filter in the fuel supply pipeline

This filter has to be replaced every 100 operating hours. It's located under the fuel tank on the fuel hose through which fuel enters the engine from the tank. To replace it:

1. Loosen the metal hose clamps, located next to the fuel valve to drain the fuel.
2. Drain the fuel to some special volume.
3. Loosen metal staples on both sides of the fuel filter.
4. Remove the filter.
5. Install new filter, paying attention to the arrow shown. The filter should be installed in the fuel passage direction.
6. Tighten the bracket on the fuel hose.

Pic 9



ACCUMULATOR MAINTENANCE

In Könnert & Söhnen models with electric start you should periodically perform battery voltage checks. The generator battery has a voltage of 12V and if the voltage is lower, you should perform battery charging with the help of an external charger.

To avoid discharging the battery, it is recommended to run the generator at least once a month for 30 minutes. If the generator is not used for a long time, please disconnect the battery from the terminals. The battery that comes with the generator does not require additional maintenance and filling of electrolyte.

GENERATOR STORAGE

Storage room has to be dry and free from dust deposits. Storage room also has to be locked away from children



IMPORTANT!



Warning! Generator is to remain ready for operation at all times. Therefore in case of device malfunctions, they are to be repaired before dismantling the generator for storage.

Long-term storage

If you do not plan to use the generator for a long time, we recommend:

- Drain the fuel from the tank.
- Drain the oil from the engine.
- Pull the manual starter until you feel light resistance so that the intake and exhaust valves are closed.
- Remove the negative terminal of the battery for the electric start models.
- Clean generator from dirt and dust.

When starting the generator after long storage, follow all procedures in reverse order.



IMPORTANT!



Pay attention to the fact that upon failed attempts to launch the generator by means of an electric start, the accumulator units may turn out de-energized, therefore prior to operation start it may be necessary to perform full accumulator unit charging.

POSSIBLE FAILURES AND SOLUTIONS

Typical failures	Possible reason	Solution
Engine does not start	Engine starting switch set to OFF position	Set the engine starting switch to ON
	No fuel	Add fuel
	Low-quality or dirty fuel is in engine	Change the fuel
Low engine power / heavy starting	Dirt in fuel tank	Clean the fuel tank
	Air filter is dirty	Clean the air filter
	Water or air in the fuel line	Pump the fuel line
Engine is overheated	Cooling fins are dirty	Clean the cooling fins
	Air filter is dirty	Clean the air filter
No voltage while engine is working	Circuit breaker is active	Turn on the circuit breaker
	Connected cables are corrupted	Check the cables; if using extension cord, change it
	Plugged device failure	Try to connect other devices
Connected devices are not working while generator is running	Generator is overloaded	Unplug some devices to reduce load
	Short circuit occurred in one of the devices connected	Unplug that device to restore the stability of a system
	Air filter is dirty	Clean the air filter
	Repetitions of an engine are lower than nominal	Contact the service center

AVERAGE POWER USAGE

Device	Average power usage
Air hair dryer	450-1200
Iron	500-1100
Electric cooking stove	800-1800
Toaster	600-1500
Coffee machine	800-1500
Air heater	1000-2000
BBQ Grill electric device	1200-2300
Vacuum cleaner	400-1000
Radio	50-250
TV set	100-400
Refrigerator	100-150
Oven	1000-2000
Freezer	100-400
Drill	400-800
Hammer drill	600-1400
Grinding machine	300-1100
Circular saw	750-1600
Electro planer	400-1000
Electro jigsaw	250-700
Angle grinder	650-2200
Compressor	750-3000
Water pump	750-3900
Electric sawing machine	1800-4000
High pressure machine	2000-4000
Electric lawn	750-3000
Air conditioner	1000-5000
Electric powered engines	550-5000
Electric fan	750-1700

25. WARRANTY SERVICE TERMS

TERMS AND CONDITIONS:

The international manufacturer warranty is 1 year. The warranty period starts from the date of purchase. In cases when warranty period is longer than 1 year according to local legislation please contact your local dealer. The Seller which sells the product is responsible for granting the warranty. Please contact the Seller for warranty. Within the warranty period, if the product fails because of defects in the production process, it will be exchanged on the same product or repaired.

The warranty card should be kept throughout the warranty period. In case of warranty card loss, a second one will not be provided. The customer must provide the warranty card and buyer's check during request for repair or exchange. Otherwise, the warranty service will not be provided. The warranty card, attached to the product during sale, should be correctly and fully completed by the retailer and customer, signed and stamped. In other cases, warranty is not considered as valid.

Provide clean product to the service center. Parts, that must be replaced, are the property of the service center.

WARRANTY DOES NOT COVER:

- If the user has failed to comply with the instructions in this manual.
- If the product features damaged or missing identification stickers or labels, serial numbers, etc.
- If product malfunction was due to improper transportation, storage and maintenance.
- In case of mechanical damages (cracks, chips, impact and fall marks, deformation of housing, power cord, plug or any other components), including those resulting from the freezing of water (ice formation), provided there are foreign objects inside the unit.
- If the product has been improperly installed and connected to the mains supply or misused.
- If the claimed malfunction cannot be diagnosed or demonstrated.
- If proper operation of the product can be restored following cleaning from dust and dirt, appropriate adjustment, maintenance, oil change, etc.
- If the product is used for business related purposes.
- If faults are detected, which have been caused by product overload. Signs of overload are molten or discolored parts as a result of high temperatures, damaged cylinder or piston surfaces, degraded piston rings or connecting rod bushes.
- The warranty does not cover the failure of the product automatic voltage regulator due to careless handling or mishandling.
- If faults are detected, which have been caused by instability of the user's power grid.
- If there are faults caused by contamination or fouling such as contamination of the fuel, oil or cooling system.
- If electrical cables or plugs show signs of mechanical or thermal damage.
- In the event of foreign liquids and objects, metal chips, etc. inside the product.
- If the malfunction is caused by the use of non-original spare parts and materials, oils, etc.
- If there are two or more faulty units that are not interconnected.
- If the damage was caused by natural factors such as dirt, dust, humidity, high or low temperature, natural disasters.
- To quick-wear parts and components (spark plugs, nozzles, pulleys, filter and safety elements, batteries, removable devices, belts, rubber seals, clutch springs, axles, manual starters, oils, gear).
- To preventive maintenance (cleaning, greasing, washing), installation and adjustment.
- If the product was tampered with, independently repaired or modified.
- In case of malfunctions resulting from normal wear and tear as a result of long-term use (end of life).
- If product operation was not stopped and continued after detecting a malfunction.
- Batteries supplied with equipment are covered by a warranty of three months.



EC Declaration of Conformity

No. 015

The following products have been tested by us with the listed standards and found in compliance with the European Community Machinery Directive 2006/42/EC, Electromagnetic compatibility Directive (EMC) 2014/26/EU Annex II.

Manufacturer: DIMAX INTERNATIONAL GmbH
Address: Hauptstr. 134, 51143 Cologne, Germany
Product: Diesel Generator «Könner & Söhnen»
Type/Model: KS 6100HDE, KS 8100HDE, KS 8100HDE-1/3 ATSR,
KS 9100HDE-1/3 ATSR, KS 9200HDES-1/3 ATSR,
KS 8200HDES-1/3 ATSR.

The statement is based on a single evaluation of one sample of above mentioned products. It does not imply an assessment of the whole production and does not permit the use of the test lab. logo. The manufacturer should ensure that all product in series production are in conformity with the product sample detailed in this report. The applicant should hold the whole technical report at disposal of the competent all the right.

Applied EC Directives: 2006/42/EC Machinery Directive
2014/26/EU Annex II Electromagnetic compatibility
Directive (EMC)

Applied Standards: EN ISO 8528-13:2016,
IEC 60034-1:2010,
EN55012:2007+A1:2009



17

Issued Date: 2016 - 07-01
Place of issue: Warsaw city
Technical expert: Homenco A.

DIMAX
International
GmbH
Steuer-Nr.: 103 5722 2493
USt-IdNr.: DE296177274

We DIMAX INTERNATIONAL GmbH hereby declare that specified above conforms covering European Parliament and Council Directives, 2006/42/EC of May 2006 Machinery Directive, Electromagnetic compatibility Directive (EMC) 2014/26/EU Annex II of February 2014. The CE mark above can be used under the responsibility of manufacturer. After completion of an EC declaration of Conformity and compliance with all relevant EC directives.

CONTACTS

Germany
ks-power.de
info@dimaxgroup.de

Poland
ks-power.pl
info.pl@dimaxgroup.de

Ukraine
ks-power.com.ua
sales@ks-power.com.ua
