

Product Overview

Thank you for purchasing this product. This is a portable lighting solution. It is specifically designed to provide lighting and power solutions to remote areas where no electricity exists. It can be easily adapted for the various environments such as garages, barns, sheds, gazebos, green house and boat docks.

Product Overlook

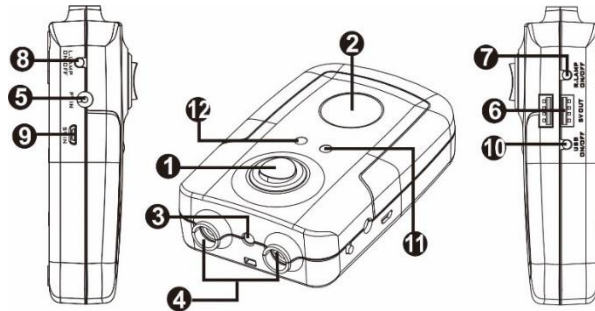

1. Main power switch
2. Built-in LED (only available for SL1 model)
3. Built-in LED (only available for SL2 model)
4. Lamp connectors
5. PV input
6. USB output port
7. Control button for right lamp
8. Control button for left lamp
9. Micro USB port
10. Control button for USB output
11. Power on: green lighting
Low battery: green flashing
Fault: Red lighting
12. Battery charging: red lighting
Full battery: green lighting

Initial Startup & Operation

1. Inspection

The following items are inside the box:

- Power pack
- Lamp with holder and cable x 2pc
- Solar panel with cable

Remove all items from its package and inspect it for damage that may have occurred during shipping. If any damage is discovered, re-pack the unit and return it to the place of purchase.

2. Charging

Before first use, please be sure to charge the battery fully. You can charge battery from either solar panel or micro USB.

Charged by solar panel: Simply connect solar panel to "PV IN " marked on power pack and place the power pack and lamps in the shaded place, where avoid exposing to sunshine directly and away from moisture.

Charged by micro USB: Simply use a micro USB power adapter to connect Utility and the micro USB connector marked with "5V IN".

3. Connect to the Outputs

There are two kinds of output connectors for different devices. Please follow below instructions to connect suitable loads to the power pack.

Two Lamps with Holders

Plug in the bundled lamp cable on the top of power pack.

Mobile Charging

There are two USB output ports for mobile device charging. Simply connect mobile devices to USB output marked with "5V OUT".

Complete lighting system diagram

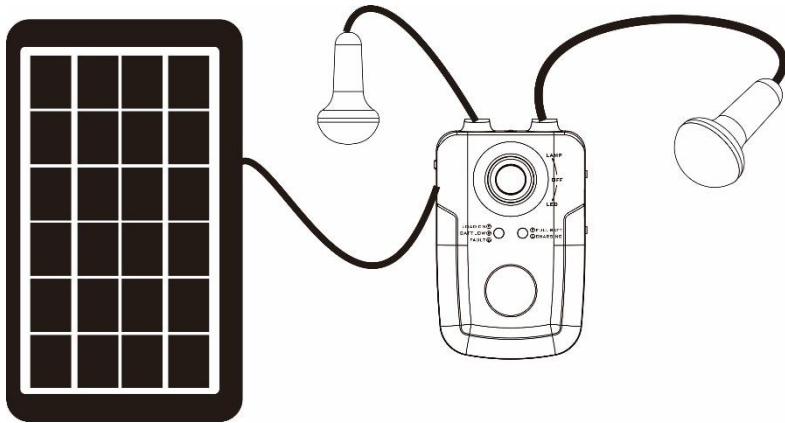

4. Operation

Lamps/Built-in LED Operation

If pressing main power switch to "I" position to turn on the unit, both connected lamps will be lighting. There are two control buttons on the two sides of power pack, one to control on/off for right lamp and the other to control on/off for left lamp.

If pressing main power switch to "II" position, lamps and built-in LED will light up at the same time.

USB OUT Operation

No matter main power switch is on "I" or "II" position, USB output port will be default off. Simply press "USB On/Off" button to turn on USB output power.

Important Safety Warning

- Please do not expose the lighting system under the blazing sun for a long time when the solar panel is charging it.
- Before first use or after prolonged storage, please turn off the switches and fully charge the battery.
- This lighting system should be charged at least once a month and each time it should be fully charged at least 6 hours. Be sure to put solar panel under direct sunlight.
- The power pack and the lamps should always be placed in a dry and shady place.
- Please keep it away from fire or any corrosives.
- Please always keep the surface of solar panel clean and in good condition.
- Any actions such as throw, drop, fall, knock are all prohibited.